

Ambitropical convexity, mean payoff games and nonarchimedean convex programming

Stephane.Gaubert@inria.fr

INRIA and CMAP, École polytechnique, IPP, CNRS

CAP21

IHES

Nov. 30 - Dec. 2, 2021

Based on works with **Akian and Guterman** (tropical geometry and games) and **Allamigeon, Benchimol, Joswig** (tropical linear programming) **Allamigeon, Skomra** (tropical semidefinite programming / nonarchimedean spectraedra), and with **Akian, Vannucci** (ambitropical)

From tropical to ambitropical convexity

- tropical analogue of modules / linear spaces

From tropical to ambitropical convexity

- tropical analogue of modules / linear spaces
- related with convexity over non-archimedean fields

From tropical to ambitropical convexity

- tropical analogue of modules / linear spaces
- related with convexity over non-archimedean fields
- equivalence with mean payoff games

From tropical to ambitropical convexity

- tropical analogue of **modules** / **linear spaces**
- related with convexity over **non-archimedean fields**
- equivalence with **mean payoff games**
- motivation from the **complexity of linear programming**; obstruction to one of the approaches to **Smale Problem # 9**: no interior point method with a self-concordant barrier is strongly polynomial.

From tropical to ambitropical convexity

- tropical analogue of **modules** / **linear spaces**
- related with convexity over **non-archimedean fields**
- equivalence with **mean payoff games**
- motivation from the **complexity of linear programming**; obstruction to one of the approaches to **Smale Problem # 9**: no interior point method with a self-concordant barrier is strongly polynomial.
- **Ambitropical convexity**, a “self-dual” extension of tropical convexity

From tropical to ambitropical convexity

- tropical analogue of **modules** / **linear spaces**
- related with convexity over **non-archimedean fields**
- equivalence with **mean payoff games**
- motivation from the **complexity of linear programming**; obstruction to one of the approaches to **Smale Problem # 9**: no interior point method with a self-concordant barrier is strongly polynomial.
- **Ambitropical convexity**, a “self-dual” extension of tropical convexity
- game, lattice and metric geometry (nonexpansive retracts) properties of ambitropical convex sets.

Part I.

Motivation: complexity issues in convex programming and games

The mean payoff problem

Mean payoff games

$G = (V, E)$ bipartite graph. $r_{ij} \in \mathbb{Z}$ price of the arc $(i, j) \in E$.

MAX and MIN move a token, alternatively (square states: MAX plays; circle states: MIN plays). n MIN nodes, m MAX nodes.

MIN always pays to MAX the price of the arc (having a negative fortune is allowed)

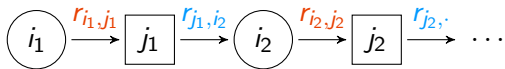

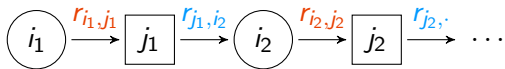

Initial position $i_1 := i$ given. Player Max wants to maximize his *mean payoff*, lim inf of:

$$\frac{r_{i_1, j_1} + r_{j_1, i_2} + r_{i_2, j_2} + \cdots + r_{j_N, i_{N+1}}}{N} \quad \text{when } N \rightarrow +\infty$$

while Player Min wants to minimize her *mean loss*, the lim sup.

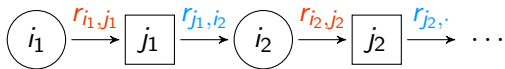

Initial position $i_1 := i$ given. Player Max wants to maximize his *mean payoff*, lim inf of:

$$\frac{r_{i_1, j_1} + r_{j_1, i_2} + r_{i_2, j_2} + \dots + r_{j_N, i_{N+1}}}{N} \quad \text{when } N \rightarrow +\infty$$

while Player Min wants to minimize her *mean loss*, the lim sup.

Theorem (Ehrenfeucht and Mycielski, 1979)

There exists a value $\chi_i \in \mathbb{R}$, and positional strategies σ and τ of Players Max and Min such that:

- with strategy σ , the mean payoff of Player Max is at least equal to χ_i ,
- with strategy τ , the mean loss of Player Min does not exceed χ_i .

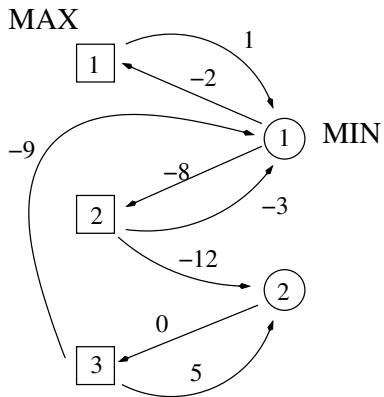

$$(\chi_1, \chi_2) = (-1, 5)$$

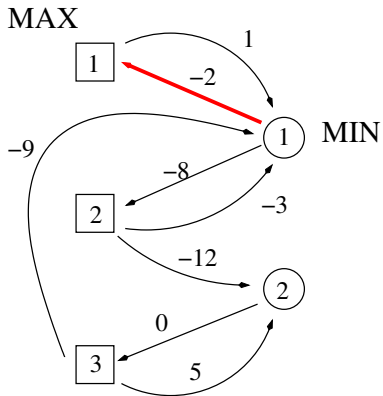

$$(\chi_1, \chi_2) = (-1, 5)$$

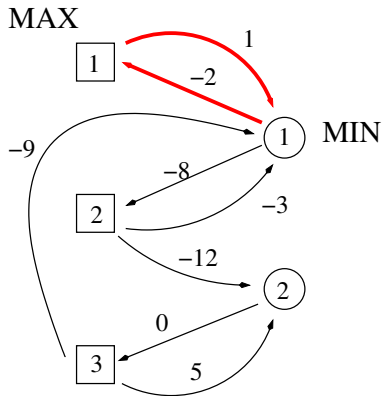

$$(\chi_1, \chi_2) = (-1, 5)$$

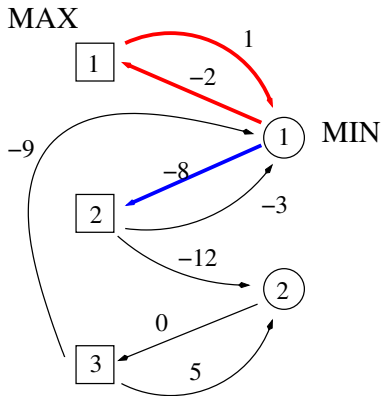

$$(\chi_1, \chi_2) = (-1, 5)$$

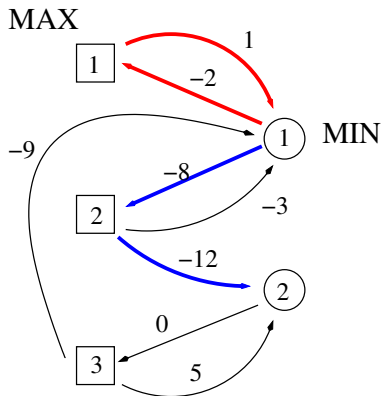

$$(\chi_1, \chi_2) = (-1, 5)$$

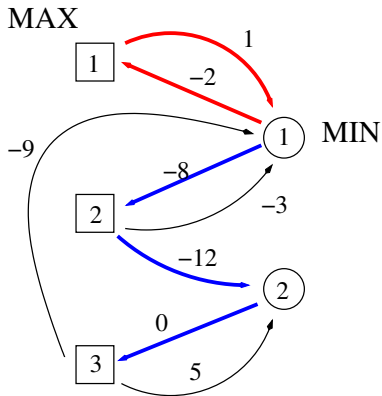

$$(\chi_1, \chi_2) = (-1, 5)$$

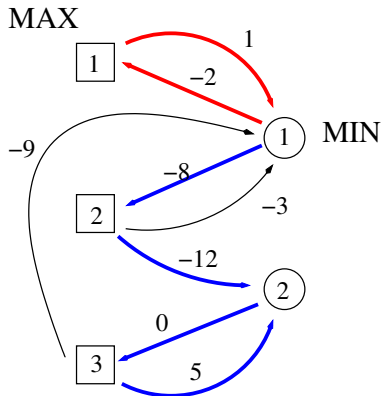

$$(\chi_1, \chi_2) = (-1, 5)$$

Problem (Gurvich, Karzanov, Khachyan 88)

Can we solve mean payoff games in polynomial time?

Problem (Gurvich, Karzanov, Khachyan 88)

Can we solve mean payoff games in polynomial time?

I.e., time $\leq \text{poly}(L)$? where L is the bitlength of the input

$$L = \sum_{ij} \log_2(1 + |r_{ij}|)$$

Mean payoff games in $\text{NP} \cap \text{coNP}$ **Zwick and Paterson [1996]**,
not known to be in P.

Linear programming

A **linear program** is an optimization problem:

$$\min c \cdot x; Ax \leq b, x \in \mathbb{R}^n ,$$

where $c \in \mathbb{Q}^n$, $A \in \mathbb{Q}^{m \times n}$, $b \in \mathbb{Q}^m$.

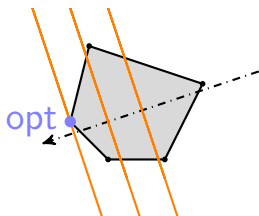

Question (9th problem of Smale)

Can we decide whether $\{x \mid Ax \leq b\}$ is empty in strongly polynomial time?

[Smale, 2000], more on strongly polynomial algo. in [Grötschel, Lovász, and Schrijver, 1993]

Question (9th problem of Smale)

Can we decide whether $\{x \mid Ax \leq b\}$ is empty in strongly polynomial time?

(weakly) polynomial time (Turing model): = execution time bounded by $\text{poly}(L)$ or equivalently $\text{poly}(n, m, L)$, L = number of bits to code the A_{ij}, b_i, c_j

[Smale, 2000], more on strongly polynomial algo. in [Grötschel, Lovász, and Schrijver, 1993]

Question (9th problem of Smale)

Can we decide whether $\{x \mid Ax \leq b\}$ is empty in strongly polynomial time?

(weakly) polynomial time (Turing model): = execution time bounded by $\text{poly}(L)$ or equivalently $\text{poly}(n, m, L)$, L = number of bits to code the A_{ij}, b_i, c_j

\neq strongly polynomial (arithmetic model): number of arithmetic operations bounded by $\text{poly}(m, n)$, **and** the size of operands of arithmetic operations is bounded by $\text{poly}(L)$.

[Smale, 2000], more on strongly polynomial algo. in [Grötschel, Lovász, and Schrijver, 1993]

Two main approaches in LP.

The simplex method (Dantzig, 1947)

Iterate over adjacent vertices (basic points) of the polyhedron while improving the objective function

$$c^T v^1 \geq c^T v^2 \geq \dots \geq c^T v^N$$

The simplex method (Dantzig, 1947)

Iterate over adjacent vertices (basic points) of the polyhedron while improving the objective function

$$c^T v^1 \geq c^T v^2 \geq \dots \geq c^T v^N$$

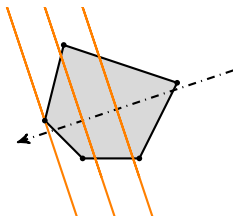

The simplex method (Dantzig, 1947)

Iterate over adjacent vertices (basic points) of the polyhedron while improving the objective function

$$c^T v^1 \geq c^T v^2 \geq \dots \geq c^T v^N$$

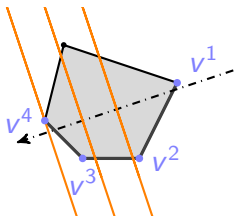

The simplex method (Dantzig, 1947)

Iterate over adjacent vertices (basic points) of the polyhedron while improving the objective function

$$c^T v^1 \geq c^T v^2 \geq \dots \geq c^T v^N$$

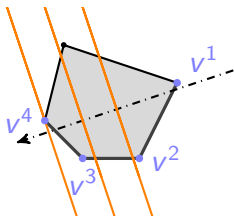

the algorithm is parametrized by a *pivoting rule*, which selects the next edge to be followed.

- Every iteration (pivoting from a basic point to the next one) can be done with a strongly polynomial complexity (linear system over \mathbb{Q}).

- Every iteration (pivoting from a basic point to the next one) can be done with a strongly polynomial complexity (linear system over \mathbb{Q}).
- It is not known whether there is a pivoting rule making a number of pivots polynomial in n, m . Superpolynomial counter-examples have been found for commonly used pivoting rules (Klee-Minty, . . . , Friedmann et al.).

- Every iteration (pivoting from a basic point to the next one) can be done with a strongly polynomial complexity (linear system over \mathbb{Q}).
- It is not known whether there is a pivoting rule making a number of pivots polynomial in n, m . Superpolynomial counter-examples have been found for commonly used pivoting rules (Klee-Minty, . . . , Friedmann et al.).
- It is not even known that the graph of the polyhedron has polynomial diameter ([polynomial Hirsch conjecture](#)), ie that the perfectly lucid pivoting rule taking the shortest path to the optimum makes a polynomial number of steps.

Interior points

For all $\mu > 0$, consider the *barrier problem*

$$\min c \cdot x - \mu \left(\sum_{i=1}^m \log(b_i - A_i x) \right), \quad b_i - A_i x > 0 \quad i \in [m]$$

$\mu \mapsto x(\mu)$ optimal solution, is the **central path**. branch of an algebraic curve. $x(0)$ is the solution of the LP.

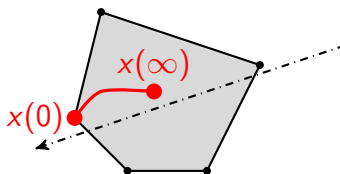

“the good convergence properties of Karmarkar’s algorithm arise from good geometric properties of the set of trajectories”, Bayer, Lagarias 89.

- Interior point methods make a **homotopy**: move in a suitable neighborhood of the central path, alternating Newton steps and decreasing μ . This leads to weakly polynomial bounds for LP.
- General interior point methods work with a **self-concordant** barrier f on a convex body K ,

$$\min_{x \in \text{int } K} c \cdot x + \mu f(x)$$

where f smooth, strictly convex, $f(x) \rightarrow \infty$ when $x \rightarrow \partial K$, and for all $x, d \in \mathbb{R}^n$, $\phi(t) = f(x + td)$ satisfies

$$\phi''' \leq 2(\phi'')^{3/2} .$$

Theory of self-concordance: **Nesterov, Nemirovski, Renegar**...

Is there a strongly polynomial interior point method?

- A theorem of **Dedieu-Malajovich-Shub (2005)**, showing that the log-barrier central path has a total curvature in $O(n)$, averaged over all 2^{n+m} LP's (cells of the arrangement of hyperplanes), $\epsilon_i A_i x \leq b_i$, $\eta_j x_j \geq 0$, $\epsilon_i, \eta_j = \pm 1$, followed by a conjecture of **Deza, Terlaky, Zinchenko**, stating that the total curvature be in $O(m)$, where m is the number of constraints, hinted towards a positive answer.

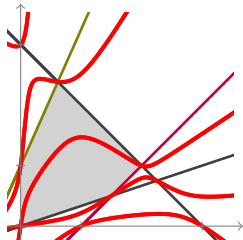

Theorem (Allamigeon, Benchimol, SG, Joswig, MPG is “not more difficult” than LP)

A semialgebraic strongly polynomial pivoting rule for LP would solve Mean Payoff Games in polynomial time (SIAM Opt 2015)

Theorem (Allamigeon, Benchimol, SG, Joswig, MPG is “not more difficult” than LP)

A semialgebraic strongly polynomial pivoting rule for LP would solve Mean Payoff Games in polynomial time (SIAM Opt 2015)

Eg, combinatorial rules, depending on signs of minors of $\begin{pmatrix} A & b \\ c & 0 \end{pmatrix}$ work.

Theorem (Allamigeon, Benchimol, SG, Joswig, MPG is “not more difficult” than LP)

A semialgebraic strongly polynomial pivoting rule for LP would solve Mean Payoff Games in polynomial time (SIAM Opt 2015)

Eg, combinatorial rules, depending on signs of minors of $\begin{pmatrix} A & b \\ c & 0 \end{pmatrix}$ work.

This is based on an [embedding theorem](#). Every mean payoff game can be encoded by a nonarchimedean linear program and complexity results can be transferred.

Theorem (Allamigeon, Benchimol, SG, Joswig, SIAM. J. Appl. Alg. Geom. 2018, SIGEST 2021)

There is a LP with $2r + 2$ variables and $3r + 4$ inequalities such that the log-barrier central path has a total curvature in $\Omega(2^r)$, and log-barrier interior point methods make $\Omega(2^r)$ on this LP.

Theorem (Universality, Allamigeon, SG, Vandame, 2021)

No self-concordant interior point method is strongly polynomial.

Although the word “tropical” appears in none of these statements, the proofs rely on tropical geometry in an essential way, through **linear programming** over **non-archimedean fields**, and **tropical modules / convex cones**.

Part II.

Operator approach to mean payoff games

v_i^k value of the game in horizon k and initial state (i, MIN) .

$$v_1^k = \min(-2 + 1 + v_1^{k-1}, -8 + \max(-3 + v_1^{k-1}, -12 + v_2^{k-1}))$$

$$v_2^k = 0 + \max(-9 + v_1^{k-1}, 5 + v_2^{k-1})$$

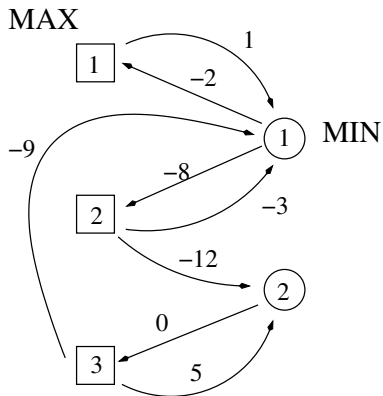

$$v^1 = (0, 0)$$

$$v^2 = (-11, 5)$$

$$v^3 = (-15, 10)$$

$$v^4 = (-16, 15)$$

$$\chi = \lim_{k \rightarrow \infty} v^k / k = (-1, 5)$$

Theorem (Shapley)

$$v^k = T(v^{k-1}), \quad v^0 = 0 .$$

The map $T : \mathbb{R}^n \rightarrow \mathbb{R}^n$ is an example of [Shapley operator](#).

Theorem (Shapley)

$$v^k = T(v^{k-1}), \quad v^0 = 0 .$$

The map $T : \mathbb{R}^n \rightarrow \mathbb{R}^n$ is an example of [Shapley operator](#).

$$[T(x)]_j = \min_{i \in [m], j \rightarrow i} \left(r_{ji} + \max_{k \in [n], i \rightarrow k} (r_{ik} + x_k) \right)$$

Definition

An abstract **Shapley operator** is a map $T : \mathbb{R}^n \rightarrow \mathbb{R}^n$ such that T is **monotone** (or **order preserving**)

$$(M) : \quad x \leq y \implies T(x) \leq T(y)$$

and **additively homogeneous**

$$(AH) : \quad T(se + x) = se + T(x), \quad \forall s \in \mathbb{R}$$

where $e = (1, \dots, 1)$ is the n -dimensional **unit vector**.

This entails that T is sup-norm nonexpansive:

$$\|T(x) - T(y)\|_{\infty} \leq \|x - y\|_{\infty}$$

Known axioms in non-linear potential theory / game theory / PDE viscosity solutions theory, e.g. **Crandall and Tartar, PAMS 80**.

General example of Shapley operator $T : \mathbb{R}^n \rightarrow \mathbb{R}^n$,

$$T_i(x) = \inf_{a \in A} \sup_{b \in B} \left(r_i^{ab} + \sum_{j \in [n]} P_{ij}^{ab} x_j \right)$$

where $P_{ij}^{ab} \geq 0$, $\sum_j P_{ij}^{ab} = 1$.

T is the **one day operator** of a repeated game, in which MIN selects a , MAX selects b , MIN pays r_i^{ab} in state i , and next state becomes j with probability P_{ij}^{ab} .

$[T^k(0)]_i$ is the value of the standard game in horizon k , starting from state i .

$[T^k(u)]_i$ is the value of a modified game, in which MAX receives an additional payment of u_j in the terminal state j .

We allow the inf and sup not to commute, this is the 'turn based' situation, MIN plays first, MAX plays next, and each player is informed of the previous action of the other player. In the original example of Shapley (1953),

$T_i(x) = \inf_{\mu \in \Delta(A)} \sup_{\nu \in \Delta(B)} \int d\mu(a)d\nu(b)(r_i^{ab} + \sum_{j \in [n]} P_{ij}^{ab} x_j)$, where $\Delta(\cdot)$ denotes the set of probability measures on a space, i.e. players choose measures on actions rather than actions. This models the situations in which MAX and MIN play simultaneously. This reduces to the general example, replacing A by $\Delta(A)$ and B by $\Delta(B)$. More generally, every Shapley operator can be written as in the general example (Kolokoltsov 92), even with deterministic transitions, allowing infinite A (Rubinov, Singer 01, Sparrow, and Gunawardena 04).

Theorem (Bewley, Kohlberg 76, Neyman 03)

The mean payoff vector

$$\lim_{k \rightarrow \infty} T^k(0)/k$$

does exist if $T : \mathbb{R}^n \rightarrow \mathbb{R}^n$ is semi-algebraic and nonexpansive in any norm.

Theorem (Bewley, Kohlberg 76, Neyman 03)

The mean payoff vector

$$\lim_{k \rightarrow \infty} T^k(0)/k$$

does exist if $T : \mathbb{R}^n \rightarrow \mathbb{R}^n$ is semi-algebraic and nonexpansive in any norm.

Finite action space and perfect information implies T piecewise linear.

Semi-algebraic is needed to deal with finite action space, player playing simultaneously (incomplete information) - Shapley's original example.

This result still holds if T is definable in a o-minimal structure, and nonexpansive, e.g., log-exp type, entropy games. . . Bolte, SG, Vigerl, MOR 14.

Winning certificates

Theorem (“subharmonic vectors” Akian, SG, Guterman, IJAC 2012)

Let T be the Shapley operator of a deterministic mean payoff game. The following are equivalent.

A Shapley operator $T : \mathbb{R}^n \rightarrow \mathbb{R}^n$ always extends continuously $(\mathbb{R} \cup \{-\infty\})^n \rightarrow (\mathbb{R} \cup \{-\infty\})^n$, the topology of $\mathbb{R} \cup \{-\infty\}$ being given by the metric $d(x, y) = |e^x - e^y|$ (Burbanks, Nussbaum, Sparrow)

Winning certificates

Theorem (“subharmonic vectors” Akian, SG, Guterman, IJAC 2012)

Let T be the Shapley operator of a deterministic mean payoff game. The following are equivalent.

- initial state j is winning, meaning that

$$0 \leq \lim_{k \rightarrow \infty} [T^k(0)]_j / k$$

A Shapley operator $T : \mathbb{R}^n \rightarrow \mathbb{R}^n$ always extends continuously $(\mathbb{R} \cup \{-\infty\})^n \rightarrow (\mathbb{R} \cup \{-\infty\})^n$, the topology of $\mathbb{R} \cup \{-\infty\}$ being given by the metric $d(x, y) = |e^x - e^y|$ (Burbanks, Nussbaum, Sparrow)

Winning certificates

Theorem (“subharmonic vectors” Akian, SG, Guterman, IJAC 2012)

Let T be the Shapley operator of a deterministic mean payoff game. The following are equivalent.

- initial state j is winning, meaning that

$$0 \leq \lim_{k \rightarrow \infty} [T^k(0)]_j / k$$

- there exists $u \in (\mathbb{R} \cup \{-\infty\})^n$, $u_j \neq -\infty$, and

$$u \leq T(u)$$

A Shapley operator $T : \mathbb{R}^n \rightarrow \mathbb{R}^n$ always extends continuously $(\mathbb{R} \cup \{-\infty\})^n \rightarrow (\mathbb{R} \cup \{-\infty\})^n$, the topology of $\mathbb{R} \cup \{-\infty\}$ being given by the metric $d(x, y) = |e^x - e^y|$ (Burbanks, Nussbaum, Sparrow)

Space of subharmonic vectors

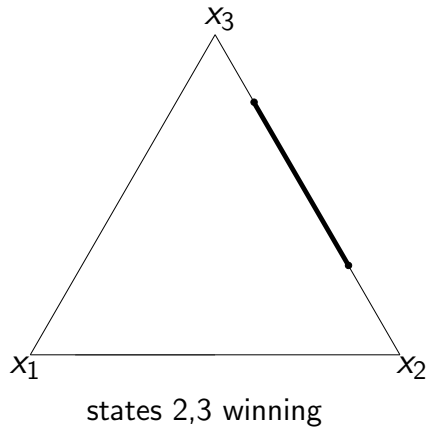
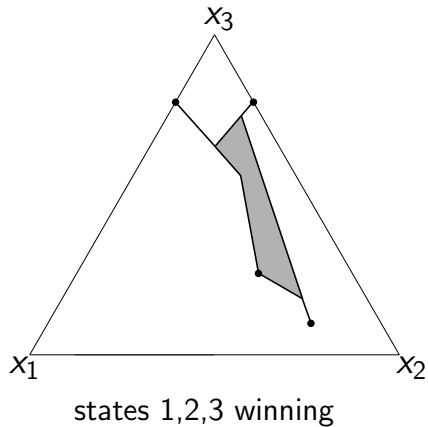

Theorem (subharmonic vectors, cont.)

For an arbitrary Shapley operator T (infinite action space and stochastic transitions allowed), the game has one initial state winning for MAX, i.e., $\exists j, \liminf_{k \rightarrow \infty} [T^k(0)]_j / k \geq 0$, iff there exists $v \in (\mathbb{R} \cup \{-\infty\})^n, v \neq (-\infty, \dots, -\infty)$, such that

$$v \leq T(v)$$

For stochastic games, the support of $v \in V$ is a winning dominion of MAX (set of winning states of MAX a.s. invariant under a strategy of MAX). Not all winning states are in winning dominions. Allamigeon, SG, Skomra, JSC 2017

Part III.

Tropical modules / convex cones

Tropical semifield $\mathbb{R}_{\max} = \mathbb{R} \cup \{-\infty\}$, equipped with

$$"a + b" = \max(a, b) \quad "a \times b" = a + b$$

$$"0" = -\infty, \quad "1" = 0$$

Tropical semifield $\mathbb{R}_{\max} = \mathbb{R} \cup \{-\infty\}$, equipped with

$$"a + b" = \max(a, b) \quad "a \times b" = a + b$$

$$"0" = -\infty, \quad "1" = 0$$

For some duality results, embed \mathbb{R}_{\max} in the complete semiring $\overline{\mathbb{R}}_{\max} := \mathbb{R} \cup \{\pm\infty\}$ (set $-\infty + (+\infty) = -\infty$ for $"0" := -\infty$ to be absorbing).

We shall also need $\mathbb{R}_{\min} := \mathbb{R} \cup \{+\infty\}$, and $\overline{\mathbb{R}}_{\min} := \mathbb{R} \cup \{\pm\infty\}$, equipped with \min as addition, instead of \max .

Examples of tropical modules over \mathbb{R}_{\max}

Scalars act on vectors by “ λx ” = $\lambda e + x$.

Exemples of tropical modules over \mathbb{R}_{\max}

Scalars act on vectors by “ λx ” = $\lambda e + x$.

\mathbb{R}_{\max}^n : free \mathbb{R}_{\max} -module, $V \subset \mathbb{R}_{\max}^n$ is a **submodule**, aka **tropical convex cone**, if for all $x, y \in V, \lambda, \mu \in \mathbb{R}_{\max}$,

$$\text{“}\lambda x + \mu y\text{”} = \sup(\lambda e + x, \mu e + y) \in V .$$

Exemples of tropical modules over \mathbb{R}_{\max}

Scalars act on vectors by “ λx ” = $\lambda e + x$.

\mathbb{R}_{\max}^n : free \mathbb{R}_{\max} -module, $V \subset \mathbb{R}_{\max}^n$ is a **submodule**, aka **tropical convex cone**, if for all $x, y \in V, \lambda, \mu \in \mathbb{R}_{\max}$,

$$\text{“}\lambda x + \mu y\text{”} = \sup(\lambda e + x, \mu e + y) \in V .$$

Since “ $\lambda \geq 0$ ” is automatic tropically, **modules = cones**.

Exemples of tropical modules over \mathbb{R}_{\max}

Scalars act on vectors by “ λx ” = $\lambda e + x$.

\mathbb{R}_{\max}^n : free \mathbb{R}_{\max} -module, $V \subset \mathbb{R}_{\max}^n$ is a **submodule**, aka **tropical convex cone**, if for all $x, y \in V, \lambda, \mu \in \mathbb{R}_{\max}$,

$$\text{“}\lambda x + \mu y\text{”} = \sup(\lambda e + x, \mu e + y) \in V .$$

Since “ $\lambda \geq 0$ ” is automatic tropically, **modules = cones**.

V is a **tropical convex set** if the same is true conditionally to “ $\lambda + \mu = 1$ ”, i.e., $\max(\lambda, \mu) = 0$.

Proposition (“subharmonic vectors”)

$V \subset \mathbb{R}_{\max}^n$ is a closed \mathbb{R}_{\max} -submodule iff there is a Shapley operator $T : \mathbb{R}_{\max}^n \rightarrow \mathbb{R}_{\max}^n$ such that $V = \{v \in \mathbb{R}_{\max}^n \mid v \leq T(v)\}$.

“Only if”, take $T = P_V$, where P_V is the operator of **best approximation**:

$$P_V(x) = \max\{v \in V \mid v \leq x\} .$$

The max belongs to the set since V stable by the sup of two vectors, and closed

Tropical adjoints

Let $A \in \mathbb{R}_{\max}^{m \times n}$, $x \in \mathbb{R}_{\max}^n$, $y \in \mathbb{R}_{\max}^n$

$$(Ax)_i = \max_{j \in [n]} (A_{ij} + x_j), \quad i \in [m]$$

Tropical adjoints

Let $A \in \mathbb{R}_{\max}^{m \times n}$, $x \in \mathbb{R}_{\max}^n$, $y \in \mathbb{R}_{\max}^m$

$$(Ax)_i = \max_{j \in [n]} (A_{ij} + x_j), \quad i \in [m]$$

$$Ax \leq y \iff x \leq A^\# y$$

Tropical adjoints

Let $A \in \mathbb{R}_{\max}^{m \times n}$, $x \in \mathbb{R}_{\max}^n$, $y \in \mathbb{R}_{\max}^m$

$$(Ax)_i = \max_{j \in [n]} (A_{ij} + x_j), \quad i \in [m]$$

$$Ax \leq y \iff x \leq A^\sharp y$$

$$(A^\sharp y)_j = \min_{i \in [m]} (-A_{ij} + y_i), \quad j \in [n]$$

The adjoint A^\sharp is a priori defined as a self-map of the order completion $\overline{\mathbb{R}}_{\max} := (\mathbb{R} \cup \{\pm\infty\})^n$ of \mathbb{R}_{\max}^n , but it does preserve \mathbb{R}^n as soon as the game has no states without actions. More on adjoints: [Cohen, SG, Quadrat, LAA 04](#)

The Shapley operator of a MPG can be written as

$$[T(v)]_j = \min_{i \in [m], j \rightarrow i} \left(-A_{ij} + \max_{k \in [n], i \rightarrow k} (B_{ik} + v_k) \right)$$

The Shapley operator of a MPG can be written as

$$[T(v)]_j = \min_{i \in [m], j \rightarrow i} \left(-A_{ij} + \max_{k \in [n], i \rightarrow k} (B_{ik} + v_k) \right)$$

$$T(v) = A^\# Bv$$

The Shapley operator of a MPG can be written as

$$[T(v)]_j = \min_{i \in [m], j \rightarrow i} \left(-A_{ij} + \max_{k \in [n], i \rightarrow k} (B_{ik} + v_k) \right)$$

$$T(v) = A^\# Bv$$

$$v \leq T(v) \iff Av \leq Bv$$

The Shapley operator of a MPG can be written as

$$[T(v)]_j = \min_{i \in [m], j \rightarrow i} \left(-A_{ij} + \max_{k \in [n], i \rightarrow k} (B_{ik} + v_k) \right)$$

$$T(v) = A^\# Bv$$

$$v \leq T(v) \iff Av \leq Bv$$

$$v \leq T(v) \iff \max_{j \in [n]} (A_{ij} + v_j) \leq \max_{j \in [n]} (B_{ij} + v_j), \quad i \in [m]$$

The Shapley operator of a MPG can be written as

$$[T(v)]_j = \min_{i \in [m], j \rightarrow i} \left(-A_{ij} + \max_{k \in [n], i \rightarrow k} (B_{ik} + v_k) \right)$$

$$T(v) = A^\# Bv$$

$$v \leq T(v) \iff Av \leq Bv$$

$$v \leq T(v) \iff \max_{j \in [n]} (A_{ij} + v_j) \leq \max_{j \in [n]} (B_{ij} + v_j), \quad i \in [m]$$

The sets of subharmonic certificates $\{v \mid Av \leq Bv\}$ is a **tropical polyhedral cone**, i.e. a set defined as the intersection of finitely many linear inequalities.

Let's see how tropical polyhedral cones look like...

Tropical hyperplanes

Given $a \in \mathbb{R}_{\max}^n$, $a \not\equiv -\infty$,

$$H := \{x \in \mathbb{R}_{\max}^n \mid \max_{i \in [n]} a_i + x_i \text{ achieved twice (at least)}\}$$

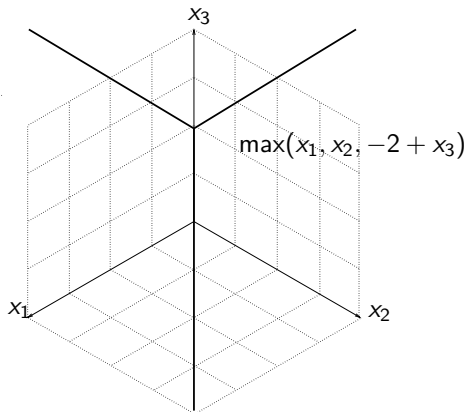

Tropical half-spaces

Given $a, b \in \mathbb{R}_{\max}^n$, $a, b \not\equiv -\infty$, $a_i = -\infty$ or $b_i = -\infty$, $\forall i$,

$$H^{\leq} := \{x \in \mathbb{R}_{\max}^n \mid \max_{i \in [n]} a_i + x_i \leq \max_{i \in [n]} b_i + x_i\}$$

Tropical half-spaces

Given $a, b \in \mathbb{R}_{\max}^n$, $a, b \not\equiv -\infty$, $a_i = -\infty$ or $b_i = -\infty$, $\forall i$,

$$H^{\leq} := \{x \in \mathbb{R}_{\max}^n \mid \max_{i \in [n]} a_i + x_i \leq \max_{i \in [n]} b_i + x_i\}$$

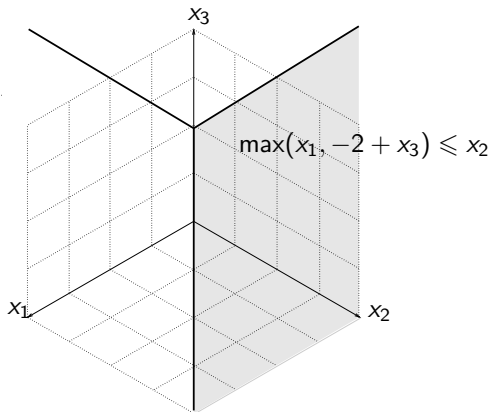

Tropical half-spaces

Given $a, b \in \mathbb{R}_{\max}^n$, $a, b \not\equiv -\infty$, $a_i = -\infty$ or $b_i = -\infty$, $\forall i$,

$$H^{\leq} := \{x \in \mathbb{R}_{\max}^n \mid \max_{i \in [n]} a_i + x_i \leq \max_{i \in [n]} b_i + x_i\}$$

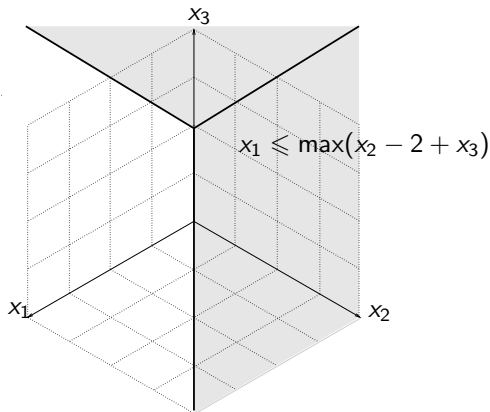

Tropical half-spaces

Given $a, b \in \mathbb{R}_{\max}^n$, $a, b \not\equiv -\infty$, $a_i = -\infty$ or $b_i = -\infty$, $\forall i$,

$$H^{\leq} := \{x \in \mathbb{R}_{\max}^n \mid \max_{i \in [n]} a_i + x_i \leq \max_{i \in [n]} b_i + x_i\}$$

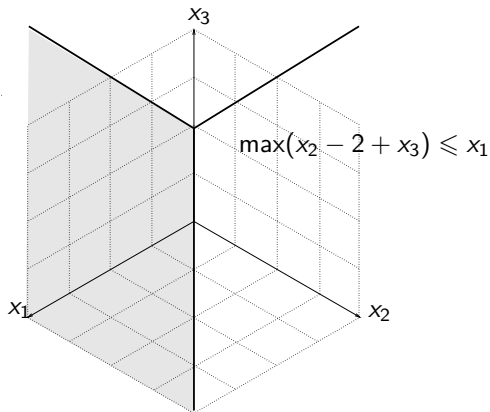

Tropical polyhedral cones

can be defined equivalently either as intersections of finitely many half-spaces or as finitely generated submodules of \mathbb{R}_{\max}^n .

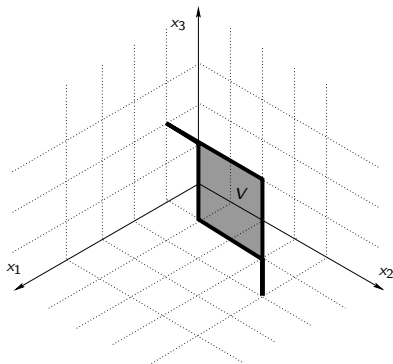

Tropical polyhedral cones

can be defined equivalently either as intersections of finitely many half-spaces or as finitely generated submodules of \mathbb{R}_{\max}^n .

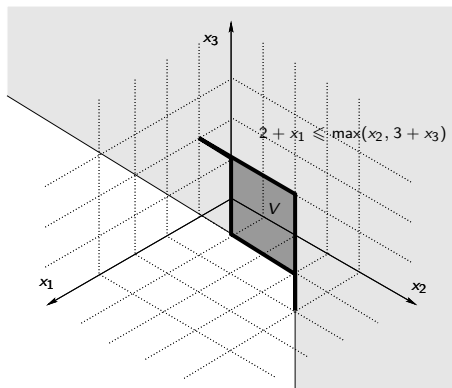

Tropical polyhedral cones

can be defined equivalently either as intersections of finitely many half-spaces or as finitely generated submodules of \mathbb{R}_{\max}^n .

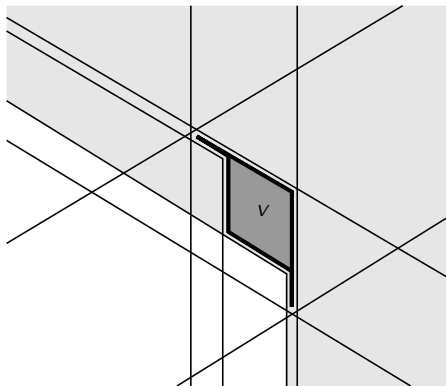

Lam, Postnikov studied alcoved polyhedra (of the root system A_n), being a generalization of Stanley's order polytopes. Alcoved polyhedra are of the form:

$$C := \{x \in \mathbb{R}^n \mid x_i - x_j \leq a_{ij}, \forall i, j\} \text{ , for some } a_{ij} \in \mathbb{R} \cup \{+\infty\}$$

Develin, Sturmfels: tropical polyhedra are polyhedral complexes whose cells are alcoved polyhedra. Example of a tropical polytope with four vertices

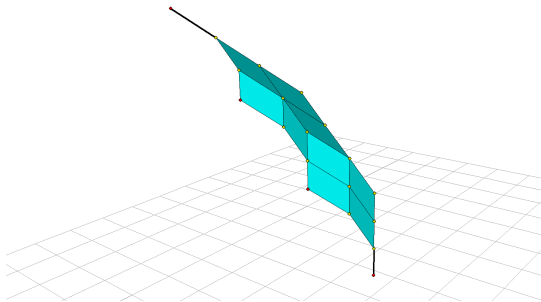

Theorem (Develin and Sturmfels, 2004)

The combinatorial type of a tropical polyhedral cone with finite generators are is determined by an arrangement of tropical hyperplanes. It is dual to a regular subdivision of the product of two simplices.

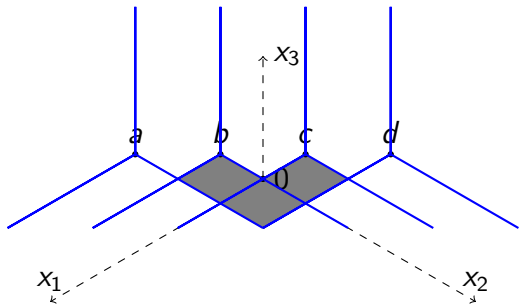

Part IV.

Link between nonarchimedean and tropical
convexity

Let \mathbb{K} be a real closed field with a nonarchimedean valuation having \mathbb{R} as the value group.

E.g., generalized Puiseux series:

$$\mathbf{x} = \mathbf{x}(t) = \sum_{i=1}^{\infty} c_i t^{\alpha_i},$$

where the sequence $(\alpha_i)_i \subset \mathbb{R}$ is strictly decreasing and either finite or unbounded and c_i are real.

Can take either formal series (**Markwig**), or rather the subfield series absolutely converging for t large enough (**van den Dries and Speissegger**), then:

$$\text{val}(\mathbf{x}) = \lim_{t \rightarrow \infty} \frac{\log |\mathbf{x}(t)|}{\log t} = \alpha_1 \quad (\text{and } \text{val}(0) = -\infty).$$

A $\mathcal{S} \subset \mathbb{K}^n$ is **basic semialgebraic** if

$$\mathcal{S} = \{(x_1, \dots, x_n) \in \mathbb{K}^n : P_i(x_1, \dots, x_n) \diamond 0, \diamond \in \{>, =\}, \forall i \in [q]\}$$

where $P_1, \dots, P_q \in \mathbb{K}[x_1, \dots, x_n]$. A **semialgebraic** set is a finite union of basic semialgebraic sets.

A $\mathcal{S} \subset \mathbb{K}^n$ is **basic semialgebraic** if

$$\mathcal{S} = \{(x_1, \dots, x_n) \in \mathbb{K}^n : P_i(x_1, \dots, x_n) \diamond 0, \diamond \in \{>, =\}, \forall i \in [q]\}$$

where $P_1, \dots, P_q \in \mathbb{K}[x_1, \dots, x_n]$. A **semialgebraic** set is a finite union of basic semialgebraic sets.

A set $S \subset \mathbb{R}^n$ is **basic semilinear** if it is of the form

$$S = \{(x_1, \dots, x_n) \in \mathbb{R}^n : \ell_i(x_1, \dots, x_n) \diamond h^{(i)}, \diamond \in \{>, =\}, \forall i \in [q]\}$$

where ℓ_1, \dots, ℓ_q are linear forms with integer coefficients, $h^{(1)}, \dots, h^{(q)} \in \mathbb{R}$. A **semilinear** set is a finite union of basic semilinear sets.

A $\mathcal{S} \subset \mathbb{K}^n$ is **basic semialgebraic** if

$$\mathcal{S} = \{(x_1, \dots, x_n) \in \mathbb{K}^n : P_i(x_1, \dots, x_n) \diamond 0, \diamond \in \{>, =\}, \forall i \in [q]\}$$

where $P_1, \dots, P_q \in \mathbb{K}[x_1, \dots, x_n]$. A **semialgebraic** set is a finite union of basic semialgebraic sets.

A set $S \subset \mathbb{R}^n$ is **basic semilinear** if it is of the form

$$S = \{(x_1, \dots, x_n) \in \mathbb{R}^n : \ell_i(x_1, \dots, x_n) \diamond h^{(i)}, \diamond \in \{>, =\}, \forall i \in [q]\}$$

where ℓ_1, \dots, ℓ_q are linear forms with integer coefficients, $h^{(1)}, \dots, h^{(q)} \in \mathbb{R}$. A **semilinear** set is a finite union of basic semilinear sets.

Theorem (Alessandrini, Adv. in Geom. 2013)

*If $\mathcal{S} \subset \mathbb{K}_{>0}^n$ is semi-algebraic, then $\text{val}(\mathcal{S}) \subset \mathbb{R}^n$ is **semilinear** and it is closed.*

A $\mathcal{S} \subset \mathbb{K}^n$ is **basic semialgebraic** if

$$\mathcal{S} = \{(x_1, \dots, x_n) \in \mathbb{K}^n : P_i(x_1, \dots, x_n) \diamond 0, \diamond \in \{>, =\}, \forall i \in [q]\}$$

where $P_1, \dots, P_q \in \mathbb{K}[x_1, \dots, x_n]$. A **semialgebraic** set is a finite union of basic semialgebraic sets.

A set $S \subset \mathbb{R}^n$ is **basic semilinear** if it is of the form

$$S = \{(x_1, \dots, x_n) \in \mathbb{R}^n : \ell_i(x_1, \dots, x_n) \diamond h^{(i)}, \diamond \in \{>, =\}, \forall i \in [q]\}$$

where ℓ_1, \dots, ℓ_q are linear forms with integer coefficients, $h^{(1)}, \dots, h^{(q)} \in \mathbb{R}$. A **semilinear** set is a finite union of basic semilinear sets.

Theorem (Alessandrini, Adv. in Geom. 2013)

*If $\mathcal{S} \subset \mathbb{K}_{>0}^n$ is semi-algebraic, then $\text{val}(\mathcal{S}) \subset \mathbb{R}^n$ is **semilinear** and it is closed.*

A constructive version follows from **Denef-Pas quantifier elimination** in valued fields, see Allamigeon, SG, Skomra, DCG 2020. See also Jell, Scheiderer and Yu arXiv:1810:05132.

Theorem (Semi-algebraic version of “Kapranov theorem”)

Consider a collection of m regions delimited by hypersurfaces:

$$\mathcal{S}_i := \{\mathbf{x} \in \mathbb{K}_{\geq 0}^n \mid \mathbf{P}_i^-(\mathbf{x}) \leq \mathbf{P}_i^+(\mathbf{x})\}, \quad i \in [m]$$

where $\mathbf{P}_i^\pm = \sum_{\alpha} \mathbf{p}_{i,\alpha}^\pm \mathbf{x}^\alpha \in \mathbb{K}_{\geq 0}[x]$, and let

$$S_i := \{x \in \mathbb{R}^n \mid \max_{\alpha}(\text{val } \mathbf{p}_{i,\alpha}^- + \langle \alpha, x \rangle) \leq \max_{\alpha}(\text{val } \mathbf{p}_{i,\alpha}^+ + \langle \alpha, x \rangle)\}$$

Then

$$\text{val}\left(\bigcap_{i \in [m]} \mathcal{S}_i\right) \subset \bigcap_{i \in [m]} \text{val}(\mathcal{S}_i) \subset \bigcap_{i \in [m]} S_i$$

and the equality holds if $\bigcap_{i \in [m]} S_i$ is the closure of its interior; in particular if the valuations $\text{val } \mathbf{p}_{i,\alpha}^\pm$ are generic.

Example 1.

$$\mathcal{S} = \{\mathbf{x} \in \mathbb{K}_{>0}^3 \mid \mathbf{x}_1^2 \leq t\mathbf{x}_2 + t^4\mathbf{x}_2\mathbf{x}_3\}$$

$$\text{val } \mathcal{S} = \{x \in \mathbb{R}^3 \mid 2x_1 \leq \max(1 + x_2, 4 + x_2 + x_3)\}$$

Example 2.

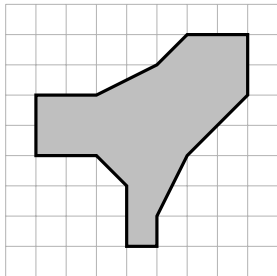

Figure: This set is the closure of its interior.

Correspondence: convex semialgebraic sets \rightarrow stochastic mean payoff games

Theorem (Allamigeon, SG, Skomra, coro of JSC 2018 + DCG 2020)

Let $C \subset \mathbb{R}^n$. TFAE:

- C is the image by val of a convex semialgebraic cone in $\mathbb{K}_{>0}^n$;
- C is a closed tropical convex cone and it is semilinear;
- $C = \{v \in \mathbb{R}^n \mid v \leq T(v)\}$, where T is a Shapley operator of a stochastic turn based zero-sum game with finite action spaces and rational transition probabilities

$$T_i(x) = \inf_{a \in A} \sup_{b \in B} (r_i^{ab} + \sum_{j \in [n]} P_{ij}^{ab} x_j)$$

$(A, B \text{ finite, } P_{ij}^{ab} \in \mathbb{Q})$.

Special case of polyhedra

Theorem

- 1 Every tropical polyhedron P can be written as $P = \text{val } \mathcal{P}$ where \mathcal{P} is a polyhedron in $\mathbb{K}_{\geq 0}^n$.
- 2 Moreover, P is the uniform (Hausdorff) limit of

$$\log_t \mathcal{P} := \left\{ \frac{\log z}{\log t} \mid z \in \mathcal{P} \right\}$$

as $t \rightarrow \infty$.

Special case of polyhedra

Theorem

- 1 Every tropical polyhedron P can be written as $P = \text{val } \mathcal{P}$ where \mathcal{P} is a polyhedron in $\mathbb{K}_{\geq 0}^n$.
- 2 Moreover, P is the uniform (Hausdorff) limit of

$$\log_t \mathcal{P} := \left\{ \frac{\log z}{\log t} \mid z \in \mathcal{P} \right\}$$

as $t \rightarrow \infty$.

Special case of polyhedra

Theorem

- 1 Every tropical polyhedron P can be written as $P = \text{val } \mathcal{P}$ where \mathcal{P} is a polyhedron in $\mathbb{K}_{\geq 0}^n$.
- 2 Moreover, P is the uniform (Hausdorff) limit of

$$\log_t \mathcal{P} := \left\{ \frac{\log z}{\log t} \mid z \in \mathcal{P} \right\}$$

as $t \rightarrow \infty$.

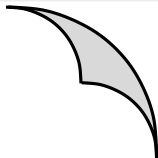

Special case of polyhedra

Theorem

- 1 Every tropical polyhedron P can be written as $P = \text{val } \mathcal{P}$ where \mathcal{P} is a polyhedron in $\mathbb{K}_{\geq 0}^n$.
- 2 Moreover, P is the uniform (Hausdorff) limit of

$$\log_t \mathcal{P} := \left\{ \frac{\log z}{\log t} \mid z \in \mathcal{P} \right\}$$

as $t \rightarrow \infty$.

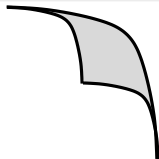

Special case of polyhedra

Theorem

- 1 Every tropical polyhedron P can be written as $P = \text{val } \mathcal{P}$ where \mathcal{P} is a polyhedron in $\mathbb{K}_{\geq 0}^n$.
- 2 Moreover, P is the uniform (Hausdorff) limit of

$$\log_t \mathcal{P} := \left\{ \frac{\log z}{\log t} \mid z \in \mathcal{P} \right\}$$

as $t \rightarrow \infty$.

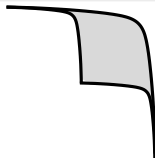

Special case of polyhedra

Theorem

- 1 Every tropical polyhedron P can be written as $P = \text{val } \mathcal{P}$ where \mathcal{P} is a polyhedron in $\mathbb{K}_{\geq 0}^n$.
- 2 Moreover, P is the uniform (Hausdorff) limit of

$$\log_t \mathcal{P} := \left\{ \frac{\log z}{\log t} \mid z \in \mathcal{P} \right\}$$

as $t \rightarrow \infty$.

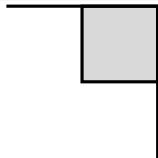

Tropical linear program

$$\min "c^T x"; \quad "A^+x + b^+ \geq A^-x + b^-"$$

$$\min \max_j c_j + x_j$$

$$\max(\max_j (A_{ij}^+ + x_j), b_i^+) \geq \max(\max_j (A_{ij}^- + x_j), b_i^-) .$$

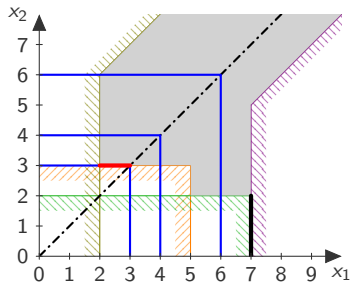

Correspondence classical \leftrightarrow tropical LP

Theorem (Allamigeon, Benchimol, SG, Joswig, SIAM J. Disc. Math)

Suppose that $\mathcal{P} = \{x \in \mathbb{K}^n \mid \mathbf{A}x + \mathbf{b} \geq 0\}$ is included in the positive orthant of \mathbb{K}^n and that the tropicalization of (\mathbf{A}, \mathbf{b}) is *sign generic*.

Then,

$$\text{val}(\mathcal{P}) = \{x \in \mathbb{R}_{\max}^n \mid "A^+x + b^+ \geq A^-x + b^-"\},$$

where $(A^+ \ b^+) = \text{val}(\mathbf{A}^+ \ \mathbf{b}^+)$ and $(A^- \ b^-) = \text{val}(\mathbf{A}^- \ \mathbf{b}^-)$. Moreover the classical and tropical polyhedron have the same combinatorics: valuation sends basic points to basic points, edges to edges, etc.

Correspondence classical \leftrightarrow tropical LP

Theorem (Allamigeon, Benchimol, SG, Joswig, SIAM J. Disc. Math)

Suppose that $\mathcal{P} = \{x \in \mathbb{K}^n \mid \mathbf{A}x + \mathbf{b} \geq 0\}$ is included in the positive orthant of \mathbb{K}^n and that the tropicalization of (\mathbf{A}, \mathbf{b}) is *sign generic*.

Then,

$$\text{val}(\mathcal{P}) = \{x \in \mathbb{R}_{\max}^n \mid "A^+x + b^+ \geq A^-x + b^-"\},$$

where $(A^+ \ b^+) = \text{val}(\mathbf{A}^+ \ \mathbf{b}^+)$ and $(A^- \ b^-) = \text{val}(\mathbf{A}^- \ \mathbf{b}^-)$. Moreover the classical and tropical polyhedron have the same combinatorics: valuation sends basic points to basic points, edges to edges, etc.

A point of a tropical polyhedron is *basic* if it saturates n inequalities.

Correspondence classical \leftrightarrow tropical LP

Theorem (Allamigeon, Benchimol, SG, Joswig, SIAM J. Disc. Math)

Suppose that $\mathcal{P} = \{x \in \mathbb{K}^n \mid \mathbf{A}x + \mathbf{b} \geq 0\}$ is included in the positive orthant of \mathbb{K}^n and that the tropicalization of (\mathbf{A}, \mathbf{b}) is *sign generic*.

Then,

$$\text{val}(\mathcal{P}) = \{x \in \mathbb{R}_{\max}^n \mid "A^+x + b^+ \geq A^-x + b^-"\},$$

where $(A^+ \ b^+) = \text{val}(\mathbf{A}^+ \ \mathbf{b}^+)$ and $(A^- \ b^-) = \text{val}(\mathbf{A}^- \ \mathbf{b}^-)$. Moreover the classical and tropical polyhedron have the same combinatorics: valuation sends basic points to basic points, edges to edges, etc.

A point of a tropical polyhedron is *basic* if it saturates n inequalities.



tropically extreme point implies basic, but not vice versa

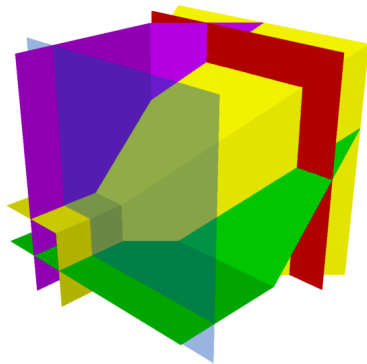
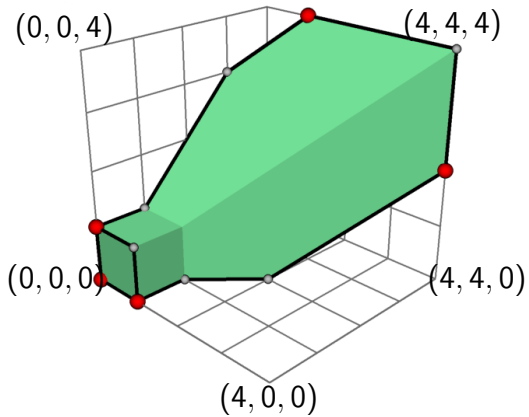

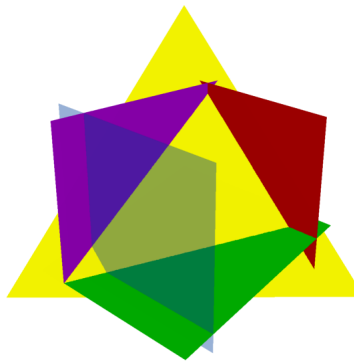
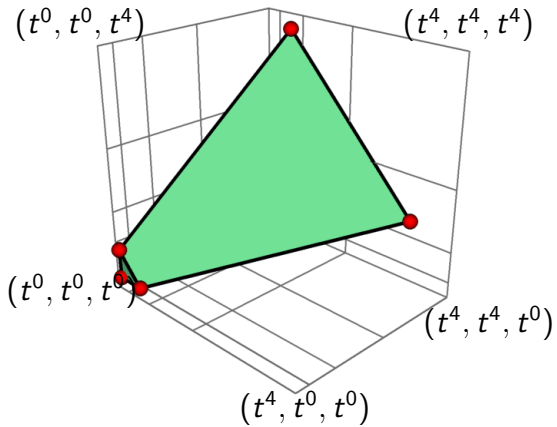

This is how the application to complexity is obtained.

Corollary (Allamigeon, Benchimol, SG, Joswig, SIAM J. Opt)

Mean payoff games are easier than combinatorial linear programming.

A mean payoff game is equivalent to a tropical linear program (feasibility problem), which can be assumed to be generic. This can be lifted to a nonarchimedean linear program. A combinatorial pivoting rule solving the linear program over the reals would solve the mean payoff game. (The rule is implemented tropically, solving optimal assignment problems.)

The counter example showing that interior point methods are not strongly polynomial is obtained by considering a linear program with a large parameter t , and working out the tropicalization of the central path.

Part V.
Ambitropical convexity

Limitation of tropical convexity

Tropical convex cones are the basic examples of tropical modules.

They are inherently asymmetric: two models of tropical convexity, max-plus and min-plus.

Considering tropically linear maps as morphisms is too restrictive. E.g., the best approximation mapping on a tropical module

$$P_V(x) = \max\{v \in V \leq v \leq x\}$$

is non-linear. Ranges of linear projectors are alcoved polyhedra (up to isomorphism).

Is there a self-dual convexity, encompassing both max-plus and min-plus convex sets, and retaining combinatorial properties and game interpretation? Answer: ambitropical convexity.

Observation

A map $T : \mathbb{R}^n \rightarrow \mathbb{R}^n$ is a Shapley operator (order preserving and additively homogeneous) iff it is nonexpansive in the weak norm $\text{top}(x) := \max_i x_i$, i.e.,

$$\text{top}(T(x) - T(y)) \leq \text{top}(x - y)$$

Compare with nonexpansive mapping in Banach spaces

$$\|T(x) - T(y)\| \leq \|x - y\|$$

Different classes of (weak) norms to different “convexities”.

Definition

A subset C of a metric space (X, d) is **metrically convex** if for any distinct points $x, y \in C$ and a decomposition $d(x, y) = \alpha + \beta$ with $\alpha, \beta > 0$, there exists a vector $z \in C$ such that $d(x, z) = \alpha$ and $d(z, y) = \beta$.

Proposition (Bruck 73)

Let X be a Banach space having the fixed point property for spheres (every nonexpansive map leaving invariant a nonempty closed convex set of a sphere has a fixed point – true if X finite dimension or strictly convex). Then, the fixed point set of a non-expansive map $T : X \rightarrow X$ is metrically convex.

Suppose $\|x - y\| = \alpha + \beta$ with $\alpha, \beta > 0$. T leaves invariant the non-empty closed convex set

$$B(x, \alpha) \cap B(y, \beta) \subset \text{Sphere}(x, \alpha) \cap \text{Sphere}(y, \beta)$$

Observation (Case of Euclidean norms)

Let C be a subset of a Hilbert space X . TFAE

- 1 C is the fixed point set of a non-expansive mapping $T : X \rightarrow X$;
- 2 C is a *non-expansive retract* of X , meaning that $C = P(X)$ where $P = P^2$ is nonexpansive;
- 3 C is closed and convex.

Proof.

(3) \Rightarrow (2): Take $P(x) = \arg \min \{ \|y - x\| \mid y \in C \}$ (best approximation).

(1) \Rightarrow (3) holds more generally in any strictly convex normed space. □

Actually, if $\dim X \geq 3$, and if every closed convex set of X is a nonexpansive retract of X , then X is a Hilbert space (Reich, JFA77)

Definition (Aronszahn and Panitchpakdi (1956))

A metric space (X, d) is hyperconvex if for any indexed family of closed balls $B(x_i, r_i)$ such that $d(x_i, x_j) \leq r_i + r_j$, the intersection $\bigcap_i B(x_i, r_i)$ is non-empty.

Equivalently, (X, d) is hyperconvex iff it is metrically convex and the family of closed balls has Helly number two.

Every hyperconvex Banach space is of the form $(C(K), \|\cdot\|_\infty)$ where K is an extremally disconnected (the closure of every open set is open) compact Hausdorff space (Nachbin 50 and Kelley 52).

Ex. $\mathbb{R}^n, \ell^\infty$ with the sup-norm.

Theorem (Aronszahn and Panitchpakdi (1956))

Let H be a metric space. TFAE

- 1 H is hyperconvex;
- 2 for every metric space M which contains H metrically, there exists a nonexpansive retraction $P : M \rightarrow H$.

Corollary

Let $C \subset \mathbb{R}^n$. TFAE

- 1 C is the fixed point set of a sup-norm non-expansive mapping of \mathbb{R}^n ;
- 2 C is a sup-norm non-expansive retract of \mathbb{R}^n ;
- 3 C is hyperconvex;

Since $\|x\|_\infty = \text{top}(x) \vee \text{top}(-x)$, top-nonexpansive implies $\|\cdot\|_\infty$ -nonexpansive.

So, we expect the set of fixed points of Shapley operators $\mathbb{R}^n \rightarrow \mathbb{R}^n$ to constitute a “generalized convexity”, refining hyperconvexity.

Consider **additive cones** $C \subset \mathbb{R}^n$, i.e., subsets inheriting the partial order of \mathbb{R}^n and stable by translation by λe for all $\lambda \in \mathbb{R}$.

Definition

An additive cone is ambitropical if it is a lattice in the induced order.

 $x \vee_C y := \min\{z \in C \mid z \geq x, z \geq y\}$ differs from the sup in \mathbb{R}^n ,
 $x \vee y = (\max(x_i, y_i))$, similarly for $x \wedge_C y$.

Theorem

Let $C \subset \mathbb{R}^n$. TFAE

- there exists a Shapley operator $T : \mathbb{R}^n \rightarrow \mathbb{R}^n$ such that $C = \{x \in \mathbb{R}^n \mid x = T(x)\}$;
- there exists a Shapley operator $P : \mathbb{R}^n \rightarrow \mathbb{R}^n$ such that $P = P^2$ and $P(\mathbb{R}^n) = C$;
- C is a closed ambitropical cone.

Proof

Lemma

An ambitropical cone is closed iff it is a conditionally complete lattice (every set bounded from above, resp. below, has a sup, resp. an inf).

If C is ambitropical and closed, the maps

$$Q_C^-(x) = \sup_C \{y \in C \mid y \leq x\} \text{ and } Q_C^+(x) = \inf_C \{y \in C \mid y \geq x\}$$

are Shapley operators, satisfying $(Q_C^+)^2 = Q_C^+$ and $Q_C^+(\mathbb{R}^n) = C$; similarly for Q_C^- . So closed ambitropical \Rightarrow Shapley retract of \mathbb{R}^n . If $C = \{x \in \mathbb{R}^n \mid x = T(x)\}$, then, for $x, y \in C$, $T(x \vee y) \geq x \vee y$, and since T is sup-norm nonexpansive with a fixed point, the orbit $\{T^k(x \vee y)\}_{k \geq 1}$ is bounded. Then:

$$x \vee_C y = \lim_{k \rightarrow \infty} T^k(x \vee y) \in \mathbb{R}^n .$$

So the fixed point set of T is ambitropical.

Ambitropical cones contain as special cases closed tropical cones (stable by sup) and their opposites, closed dual tropical cones (stable by inf);

closed additive cones stable by sup and inf		alcoved polyhedra
closed tropical cone		$\{x \in \mathbb{R}^n \mid x \leq T(x)\}$
closed dual tropical cone		$\{x \in \mathbb{R}^n \mid x \geq T(x)\}$
ambitropical cones		$\{x \in \mathbb{R}^n \mid x = T(x)\}$

where T is a Shapley operator.

Flip invariance. If E is ambitropical, then $-E$ is ambitropical, corresponding to the fixed point of $x \mapsto -T(-x)$.

C^{\max} : = set of suprema of family of elements of C bounded from above; C^{\min} defined dually.

$$P_C^{\max}(x) = \sup\{y \in C^{\max} \mid y \leq x\}, \quad P_C^{\min}(x) = \inf\{y \in C^{\min} \mid y \geq x\}.$$

Theorem

If C is ambitropical and closed, then,

$$Q_C^-(x) := \sup_C\{y \in C \mid y \leq x\} = P_C^{\min} \circ P_C^{\max}(x)$$

$$Q_C^+(x) := \inf_C\{y \in C \mid y \geq x\} = P_C^{\max} \circ P_C^{\min}(x)$$

Proof. Check first that $P_C^{\max}(x) = \sup\{z \in C \mid z \leq x\}$, and dual for min. Then,

$$\begin{aligned} P_C^{\min}(P_C^{\max}(x)) &= \inf\{y \in C \mid y \geq P_C^{\max}(x)\} \\ &= \inf\{y \in C \mid y \geq \sup\{z \in C \mid z \leq x\}\} \\ &= \inf\{y \in C \mid (z \in C, z \leq x) \implies z \leq y\} \\ &= \sup^C\{z \in C \mid z \leq x\} = Q_C^-(x) \end{aligned}$$

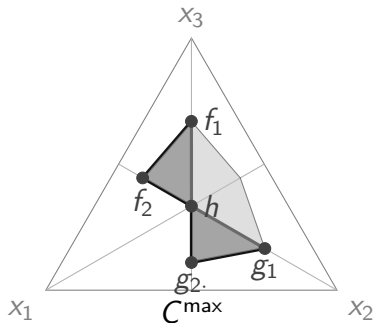
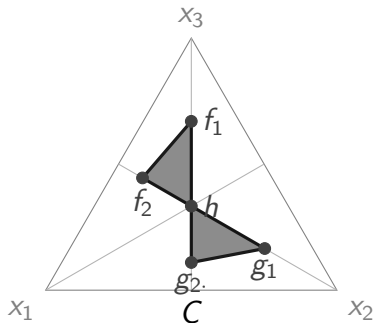

$$Q_C^-(x) = \begin{pmatrix} (x \wedge y \wedge (1+z)) \vee (x \wedge (1+y) \wedge z) \vee (y \wedge z \wedge (1+x)) \\ y \wedge (1+x) \wedge (1+z) \\ z \wedge (1+y) \wedge (1+x) \end{pmatrix}$$

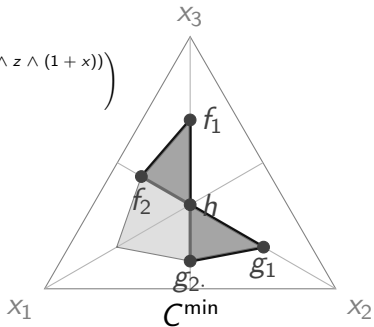

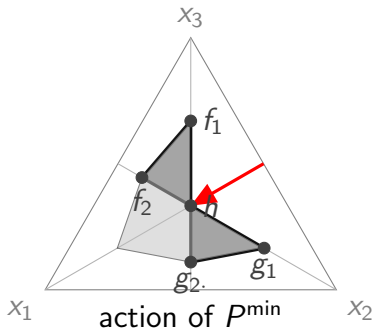
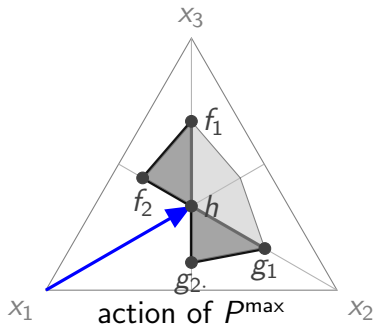
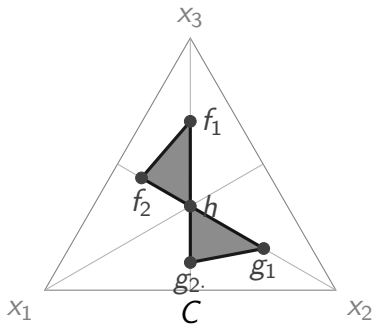

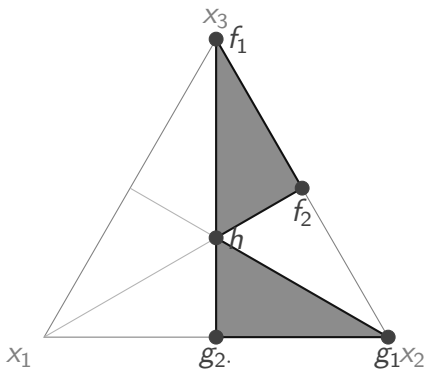

C in grey. C^{\min} and C^{\max} both consist of C union of the blue triangle (g_1, h, f_2) . So $C \subsetneq \text{range } P_C^{\min} \circ P_C^{\max}$ is not ambitropical.

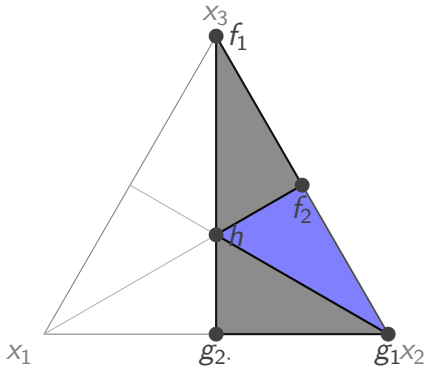

C in grey. C^{\min} and C^{\max} both consist of C union of the blue triangle (g_1, h, f_2) . So $C \subsetneq \text{range } P_C^{\min} \circ P_C^{\max}$ is not ambitropical.

Theorem (Flip-flop property)

Let C be an additive cone in \mathbb{R}^n . TFAE:

- $C = P(\mathbb{R}^n)$ where $P = P^2$ is a Shapley operator;
- For all $z \in \mathbb{R}^n$, $[P_C^{\max}(z), P_C^{\min}(z)]$ meets C ;
- For all $z \in C^{\max}$, $P^{\min}(z) \in C$;
- For all $z \in C^{\min}$, $P^{\max}(z) \in C$.

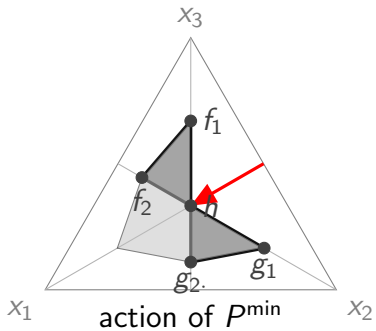
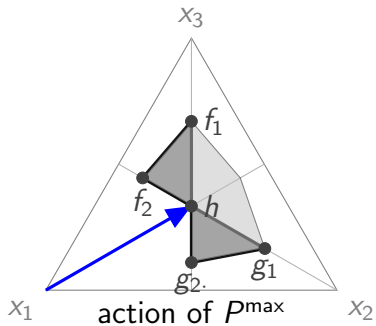
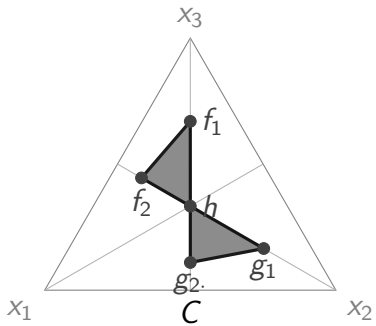



The intersection of ambitropical cones is generally not ambitropical.

However, there is a notion of ambitropical hull defined **up to isomorphism**:

Theorem

Let C be an additive cone in \mathbb{R}^n . All closed ambitropical sets containing C that are minimal for inclusion are isomorphic (morphisms are Shapley operators).

The sets $P_C^{\max} \circ P_C^{\min}(\mathbb{R}^n)$ and $P_C^{\min} \circ P_C^{\max}(\mathbb{R}^n)$ are two (isomorphic) examples of ambitropical closure of C .

Define **ambitropical polyhedra** to be ambitropical cones that are polyhedral complexes whose cells are alcoved polyhedra.

A Shapley operator $T : \mathbb{R}^n \rightarrow \mathbb{R}^n$ is **finitely generated** if we can find $p \geq 1$ and matrices $A, B \in \mathbb{R}_{\max}^{p \times n}$ such that i.e.,

$$T_i(x) = \min_{j \in [p]} (-A_{ji} + \max_{k \in [n]} (B_{jk} + x_k)) .$$

I.e., T represents a deterministic game with finite action spaces.

Game significance of fixed points of the Shapley operator

Suppose that $T(u) = u + \lambda e$, $\lambda \in \mathbb{R}$. Then, the mean payoff is equal to λ , for all initial states.

The set of such eigenvectors u is the fixed point set of $-\lambda + T$, so an ambitropical convex set.

An eigenvector u determines a pair of positional strategies σ^* and π^* of Min and Max. In state i , let Min move to any state j achieving the minimum in

$$T_i(u) = \min_j (- A_{ji} + \max_{\ell} (B_{j\ell} + u_{\ell}))$$

and similarly, in state j , let Max move to any state ℓ achieving the maximum.

Observation

The pair of strategies σ^*, π^* of Players Min and Max arising from u is *u-calibrated*, meaning that:

- By playing σ^* , Player Min can guarantee that, whatever Max does, and for all horizons k ,

$$-A_{j_0 i_0} + B_{j_0 i_1} + \cdots + -A_{j_{k-1} i_{k-1}} + B_{j_{k-1} i_k} \leq u_{i_0} - u_{j_k} + k\lambda ,$$

where $i_0, j_0, i_1, j_1, \dots, i_k$ is the sequence of states that are visited;

- By playing π^* , Player Max can guarantee that, whatever Min does, and for all horizons k ,

$$-A_{j_0 i_0} + B_{j_0 i_1} + \cdots + -A_{j_{k-1} i_{k-1}} + B_{j_{k-1} i_k} \geq u_{i_0} - u_{j_k} + k\lambda .$$

Calibrated strategies yield optimal strategies in the mean payoff problem (but not vice versa).

This extends the notion of calibrated trajectory introduced by Fathi in the one player case. Fathi considers weak-KAM solutions, i.e., solutions u of the Hamilton-Jacobi PDE $\lambda = H(x, \frac{\partial u}{\partial x})$ where $H(x, \cdot)$ is convex = infinite dimensional max-plus eigenspaces.

Theorem

Let $C \subset \mathbb{R}^n$. TFAE

- C is an ambitropical polyhedron;
- C is the fixed point set of a finitely generated Shapley operator;
- there exists a finitely generated Shapley operator $P = P^2$; such that $C = P(\mathbb{R}^n)$
- C is a closed ambitropical cone, $\text{clo}^\downarrow C^{\max}$ is a finitely generated submodule of \mathbb{R}_{\max}^n , and $\text{clo}^\uparrow C^{\min}$ is a finitely generated submodule of \mathbb{R}_{\min}^n .

$\text{clo}^\downarrow(\cdot)$ denotes the closure in \mathbb{R}_{\max}^n by taking limits of nonincreasing sequences, and dually for $\text{clo}^\uparrow \cdot$.

Hence, an ambitropical cone can be represented in an equational way, or by means of generators of $\text{clo}^\downarrow C^{\max}$ and $\text{clo}^\uparrow C^{\min}$.

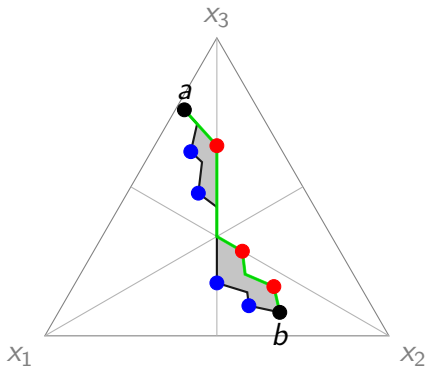

An ambitropical polyhedron

Blue and black: generators of $\text{clo}^\downarrow C^{\max}$; Red and black: generators of $\text{clo}^\uparrow C^{\min}$. In Green: an example of geodesic in Hilbert's seminorm.

An ambitropical cone C is **homogeneous** if for all $\alpha > 0$ and $x \in C$, $\alpha x \in C$.

Proposition

If C is an ambitropical polyhedron, then, its tangent cone at any point is a homogeneous ambitropical polyhedron.

If C is a homogeneous ambitropical polyhedron, then the **skeleton** of C is $\text{Sk}(C) := C \cap \{0, 1\}^n$.

A **Weyl cell** associated to an ordered partition $[n] = I_1 \cup \dots \cup I_s$ a set of the form

$$W = \{x \in \mathbb{R}^n \mid (i \in I_r, j \in I_s, r \leq s) \implies x_i \leq x_j\} .$$

If $I_1 = \{i_1\}, \dots, I_n = \{i_n\}$, this specializes to

$$W = \{x \in \mathbb{R}^n \mid x_{i_1} \leq \dots \leq x_{i_n}\} .$$

Theorem

- *The map $C \mapsto \text{Sk}(C)$ sets up of bijective correspondence between homogeneous ambitropical polyhedra and subsets of $\{0, 1\}^n$ that are lattices in the induced order (equivalently, order preserving retracts of $\{0, 1\}^n$).*
- *A homogeneous ambitropical polyhedron is the support of a polyhedral complex composed of Weyl cells in bijection with chains in the lattice $\text{Sk}(C)$.*

Order preserving retracts of complete lattices studied in Crapo (1982).

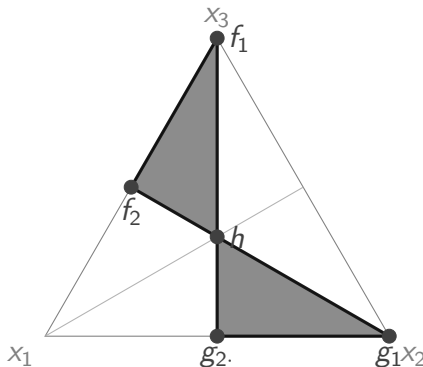
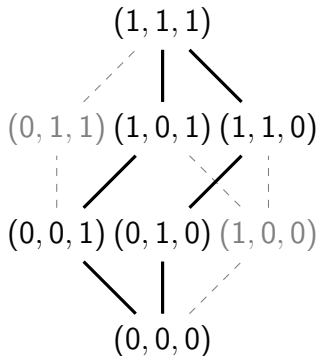

$$C = \{x \in \mathbb{R}^3 \mid x_3 \geq x_1 \geq x_2\} \cup \{x_2 \geq x_1 \geq x_3\}.$$

Concluding remarks

- Tropical convex sets have the following properties:
 - ① characterize the winner in mean payoff games;
 - ② coincide with sub-fixed point sets of Shapley operators;
 - ③ admit external and internal representations;
 - ④ are the image by the valuation of non-archimedean convex sets;
 - ⑤ can be characterized combinatorially (combinatorial types of tropical polyhedra are duals of regular subdivisions of products of two simplices).
- Ambitropical convex sets provides a generalization (or even a refinement) of the first three properties.
- Link between ambitropical convexity and the theory of nonexpansive retracts (subtheory of hyperconvexity).
- Nonarchimedean interpretation is still missing. Combinatorial characterization in the homogeneous case (\sim lattices in $\{0, 1\}^n$).

References: on Ambitropical convexity, Akian, SG, Vannucci,
arXiv:2108.07748

On the application of tropical convexity to complexity of linear
programming, Allamigeon, Benchimol, SG, Joswig, SIAM SIGEST, 2021.

More references below.

Thank you !

- M. Akian, S. Gaubert, and A. Guterman. Tropical polyhedra are equivalent to mean payoff games. *International Journal of Algebra and Computation*, 22(1):125001 (43 pages), 2012. doi: 10.1142/S0218196711006674.
- X. Allamigeon, P. Benchimol, S. Gaubert, and M. Joswig. Tropicalizing the simplex algorithm. *SIAM J. Disc. Math.*, 29(2): 751–795, 2015a. doi: 10.1137/130936464.
- X. Allamigeon, S. Gaubert, and M. Skomra. Solving generic nonarchimedean semidefinite programs using stochastic game algorithms. *Journal of Symbolic Computation*, 85:25–54, 2018. doi: 10.1016/j.jsc.2017.07.002.
- Xavier Allamigeon, Pascal Benchimol, and Stéphane Gaubert. The tropical shadow-vertex algorithm solves mean payoff games in polynomial time on average. In *Proceedings of the 41st International Colloquium on Automata, Languages, and Programming (ICALP)*, number 8572 in Lecture Notes in Computer Science, pages 89–100. Springer, 2014.
- Xavier Allamigeon, Pascal Benchimol, Stéphane Gaubert, and Michael Joswig. Combinatorial simplex algorithms can solve mean payoff games. *SIAM J. Opt.*, 24(4):2096–2117, 2015b. doi: 10.1137/140953800.
- Xavier Allamigeon, Stéphane Gaubert, and Mateusz Skomra. The tropical analogue of the Helton–Nie conjecture is true. *Journal of Symbolic Computation*, 91:129 – 148, 2019. ISSN 0747-7171. doi: <https://doi.org/10.1016/j.jsc.2018.06.017>. URL <http://www.sciencedirect.com/science/article/pii/S0747717118300828>. MEGA 2017, Effective Methods in Algebraic Geometry, Nice (France), June 12-16, 2017.
- Xavier Allamigeon, Stéphane Gaubert, and Mateusz Skomra. Tropical spectrahedra. *Discrete Comput. Geom.*, 63:507–548, 2020. doi: 10.1007/s00454-020-00176-1.
- G. Cohen, S. Gaubert, and J.-P. Quadrat. Duality and separation theorems in idempotent semimodules. *Linear Algebra and Appl.*, 379:395–422, 2004. URL <http://arxiv.org/abs/math.FA/0212294>.
- J.A. De Loera, B. Sturmfels, and C. Vinzant. The central curve in linear programming. *Foundations of Computational Mathematics*, 12(4):509–540, 2012.
- M. Develin and B. Sturmfels. Tropical convexity. *Doc. Math.*, 9:1–27, 2004. ISSN 1431-0635.
- M. Develin, F. Santos, and B. Sturmfels. On the rank of a tropical matrix. In *Combinatorial and computational geometry*, volume 52 of *Math. Sci. Res. Inst. Publ.*, pages 213–242. Cambridge Univ. Press, Cambridge, 2005.
- A. Deza, T. Terlaky, and Y. Zinchenko. Polytopes and arrangements: diameter and curvature. *Operations Research Letters*, 36(2):215–222, 2008.
- A. Ehrenfeucht and J. Mycielski. Positional strategies for mean payoff games. *International Journal of Game Theory*, 8(2): 109–113, 1979.
- M. Forsberg, M. Passare, and A. Tsikh. Laurent determinants and arrangements of hyperplane amoebas. *Adv. Math.*, 151(1): 45–70, 2000. ISSN 0001-8708.

- S. Gaubert and R. Katz. Minimal half-spaces and external representation of tropical polyhedra. *Journal of Algebraic Combinatorics*, 33(3):325–348, 2011. doi: 10.1007/s10801-010-0246-4, arXiv:arXiv:0908.1586,.
- I. Gelfand, M. Kapranov, and A. Zelevinsky. *Discriminants, resultants, and multidimensional determinants*. Birkhäuser, 1994.
- M. Grötschel, L. Lovász, and A. Schrijver. *Geometric algorithms and combinatorial optimization*, volume 2 of *Algorithms and Combinatorics*. Springer-Verlag, Berlin, second edition, 1993. ISBN 3-540-56740-2. doi: 10.1007/978-3-642-78240-4. URL <http://dx.doi.org/10.1007/978-3-642-78240-4>.
- I. Itenberg, G. Mikhalkin, and E. Shustin. *Tropical algebraic geometry*. Oberwolfach seminars. Birkhäuser, 2007.
- M. Joswig. Tropical halfspaces. In *Combinatorial and computational geometry*, volume 52 of *Math. Sci. Res. Inst. Publ.*, pages 409–431. Cambridge Univ. Press, Cambridge, 2005. Also eprint arXiv:math.CO/0312068.
- G. Mikhalkin. Amoebas of algebraic varieties and tropical geometry. In *Different faces of geometry*, volume 3 of *Int. Math. Ser. (N. Y.)*, pages 257–300. Kluwer/Plenum, New York, 2004. URL <http://arxiv.org/abs/math.AG/0403015>.
- G. Mikhalkin. Enumerative tropical algebraic geometry in \mathbb{R}^2 . *J. Amer. Math. Soc.*, 18(2):313–377, 2005. ISSN 0894-0347.
- S. Mizuno, M. J. Todd, and Y. Ye. On adaptive-step primal-dual interior-point algorithms for linear programming. *Mathematics of Operations Research*, 18(4):964–981, 1993.
- S. Smale. Mathematical problems for the next century. In *Mathematics: frontiers and perspectives*, pages 271–294. Amer. Math. Soc., Providence, RI, 2000.
- U. Zwick and M. Paterson. The complexity of mean payoff games on graphs. *Theoret. Comput. Sci.*, 158(1-2):343–359, 1996. ISSN 0304-3975.

Part VI.
Tropicalization of the central path

Primal-dual central path

$$\text{minimize} \quad \frac{c^\top x}{\mu} - \sum_{j=1}^n \log(x_j) - \sum_{i=1}^m \log(w_i) \quad (1)$$

$$\text{subject to} \quad Ax + w = b, \quad x > 0, \quad w > 0.$$

$$\begin{aligned} Ax + w &= b \\ -A^\top y + s &= c \\ w_i y_i &= \mu \quad \text{for all } i \in [m] \\ x_j s_j &= \mu \quad \text{for all } j \in [n] \\ x, w, y, s &> 0. \end{aligned} \quad (2)$$

For any $\mu > 0$, $\exists!$ $(x^\mu, w^\mu, y^\mu, s^\mu) \in \mathbb{R}^n \times \mathbb{R}^m \times \mathbb{R}^m \times \mathbb{R}^n$. The **central path** is the image of the map $\mathcal{C} : \mathbb{R}_{>0} \rightarrow \mathbb{R}^{2m+2n}$ which sends $\mu > 0$ to the vector $(x^\mu, w^\mu, y^\mu, s^\mu)$.

The tropical central path

Assume now that $\mathbf{A}(t)$, $\mathbf{b}(t)$, $\mathbf{c}(t)$ have entries in \mathbb{K} (absolutely converging Puiseux series with real exponents, $t \rightarrow \infty$).

The **tropical central path** is the image by the valuation of the central path. It is the log-limit, taking the parameter $\mu := t^\lambda$,

$$\mathcal{C}^{\text{trop}} : \lambda \mapsto \lim_{t \rightarrow \infty} \frac{\log \mathcal{C}(t^\lambda)}{\log t}. \quad (3)$$

$\mathcal{C}^{\text{trop}}$ can be computed by combinatorial means.

barycenter of a (compact) tropical polyhedron \mathcal{P}

= **greatest point** of the set \mathcal{P} w.r.t.
the coordinate-wise order \leq

barycenter of a (compact) tropical polyhedron \mathcal{P}

= **greatest point** of the set \mathcal{P} w.r.t.
the coordinate-wise order \leq

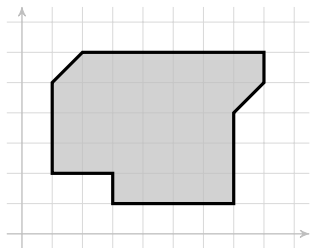

barycenter of a (compact) tropical polyhedron \mathcal{P}

= **greatest point** of the set \mathcal{P} w.r.t.
the coordinate-wise order \leq

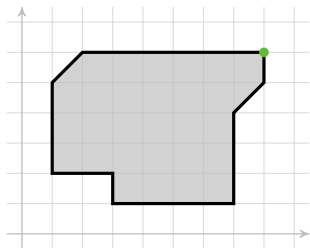

barycenter of a (compact) tropical polyhedron \mathcal{P}

= **greatest point** of the set \mathcal{P} w.r.t.
the coordinate-wise order \leq

Let \mathcal{P} be the feasible set of $\mathbf{LP}(\mathbf{A}, \mathbf{b}, \mathbf{c})$:

$$\mathcal{P} := \{(\mathbf{x}, \mathbf{w}) \in \mathbb{K}_{\geq 0}^{n+m} : \mathbf{Ax} + \mathbf{w} = \mathbf{b}\}.$$

Assume, for simplicity, $\mathbf{b}, \mathbf{c} \geq 0$.

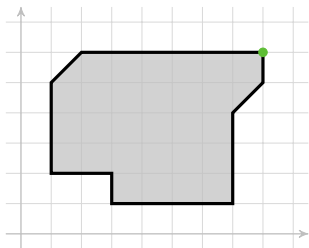

barycenter of a (compact) tropical polyhedron \mathcal{P}

= **greatest point** of the set \mathcal{P} w.r.t.
the coordinate-wise order \leq

Let \mathcal{P} be the feasible set of $\mathbf{LP}(\mathbf{A}, \mathbf{b}, \mathbf{c})$:

$$\mathcal{P} := \{(\mathbf{x}, \mathbf{w}) \in \mathbb{K}_{\geq 0}^{n+m} : \mathbf{Ax} + \mathbf{w} = \mathbf{b}\}.$$

Assume, for simplicity, $\mathbf{b}, \mathbf{c} \geq 0$.

Theorem

The image under val of the point $(\mathbf{x}^\mu, \mathbf{w}^\mu)$ of the primal central path is given by the barycenter of the tropical polyhedron:

$$\text{val}(\mathcal{P}) \cap \{(\mathbf{x}, \mathbf{w}) \in \mathbb{R}_{\max}^{n+m} : \text{val}(\mathbf{c})^\top \odot \mathbf{x} \leq \text{val}(\boldsymbol{\mu})\}.$$

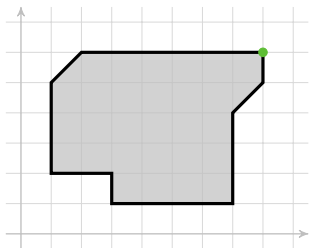

$-10i[t]$

$$\mathcal{P} : \begin{cases} \mathbf{x}_1 + \mathbf{x}_2 \leq 2 \\ t\mathbf{x}_1 \leq 1 + t^2\mathbf{x}_2 \\ t\mathbf{x}_2 \leq 1 + t^3\mathbf{x}_1 \\ \mathbf{x}_1 \leq t^2\mathbf{x}_2 \\ \mathbf{x}_1, \mathbf{x}_2 \geq 0 \end{cases} \quad \text{val}(\mathcal{P}) : \begin{cases} \max(\mathbf{x}_1, \mathbf{x}_2) \leq 0 \\ 1 + \mathbf{x}_1 \leq \max(0, 2 + \mathbf{x}_2) \\ 1 + \mathbf{x}_2 \leq \max(0, 3 + \mathbf{x}_1) \\ \mathbf{x}_1 \leq 2 + \mathbf{x}_2 \end{cases}$$

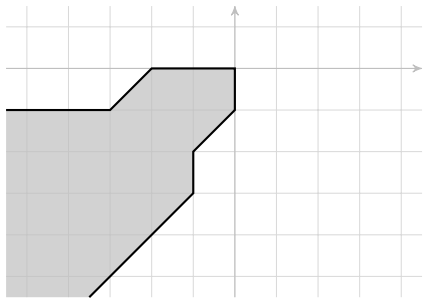

The counter example ...

$$\begin{aligned}
\min \quad & \mathbf{v}_0 \\
\text{s.t.} \quad & \mathbf{u}_0 \leq t^1 \\
& \mathbf{v}_0 \leq t^2 \\
& \mathbf{v}_i \leq t^{(1-\frac{1}{2^i})}(\mathbf{u}_{i-1} + \mathbf{v}_{i-1}) \quad \text{for } 1 \leq i \leq r \quad \text{LW}_r \\
& \mathbf{u}_i \leq t^1 \mathbf{u}_{i-1} \quad \text{for } 1 \leq i \leq r \\
& \mathbf{u}_i \leq t^1 \mathbf{v}_{i-1} \quad \text{for } 1 \leq i \leq r \\
& \mathbf{u}_r \geq 0, \mathbf{v}_r \geq 0
\end{aligned}$$

Theorem (Allamigeon, Benchimol, SG, Joswig SIAGA 2018)

For t large enough, the total curvature of the central path is $\geq (2^{r-1} - 1)\pi/2$.

Large enough: $\log_2 t = \Omega(2^r)$.

$$\begin{array}{ll}
u_0 \leq t^1 & u_0 \leq 1 \\
v_0 \leq t^2 & v_0 \leq 2 \\
v_i \leq t^{(1-\frac{1}{2^i})}(u_{i-1} + v_{i-1}) & v_i \leq 1 - \frac{1}{2^i} + \max(u_{i-1}, v_{i-1}) \\
u_i \leq t^1 u_{i-1} & u_i \leq 1 + u_{i-1} \\
u_i \leq t^1 v_{i-1} & u_i \leq 1 + v_{i-1} \\
u_r \geq 0, v_r \geq 0 & c^\top x = v_0 \leq \lambda
\end{array}$$

The tropical central path is given by

$$\begin{aligned}
u_0 &= 1 \\
v_0 &= \min(2, \lambda) \\
v_i &= 1 - \frac{1}{2^i} + \max(u_{i-1}, v_{i-1}) \\
u_i &= 1 + \min(u_{i-1}, v_{i-1})
\end{aligned}$$

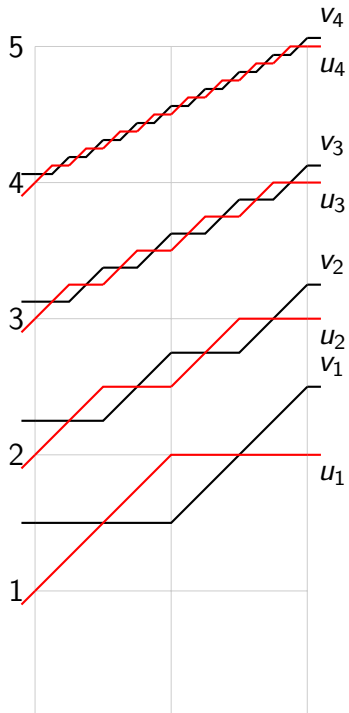

Corollary (Interior point methods are not strongly polynomial,
Allamigeon, Benchimol, SG, Joswig SIAGA 2018)

Suppose that

$$t > \left(\frac{((10r - 1)!)^8}{1 - \theta} \right)^{2^{r+2}}.$$

Then, any log-barrier interior point method which stays in a wide neighborhood of the primal-dual central path of $LW_r(t)$ needs to perform at least 2^{r-1} iterations to reduce the duality measure from t^2 to 1.

Corollary (Interior point methods are not strongly polynomial,
Allamigeon, Benchimol, SG, Joswig SIAGA 2018)

Suppose that

$$t > \left(\frac{((10r - 1)!)^8}{1 - \theta} \right)^{2^{r+2}}.$$

Then, any log-barrier interior point method which stays in a wide neighborhood of the primal-dual central path of $LW_r(t)$ needs to perform at least 2^{r-1} iterations to reduce the duality measure from t^2 to 1.

Wide neighborhood:

$$\mathcal{N}_t^{-\infty}(\mu) := \left\{ (x, w, s, y) \in \mathcal{P}(t) \times \mathcal{Q}(t) : \bar{\mu}(x, w, s, y) = \mu \text{ and } \begin{pmatrix} xs \\ wy \end{pmatrix} \geq (1 - \theta)\mu e \right\}$$
$$\bar{\mu}(x, w, s, y) := \frac{1}{m+n} (x^\top s + w^\top y)$$

and $\theta \in]0, 1[$ parametrizes the size of the neighborhood.

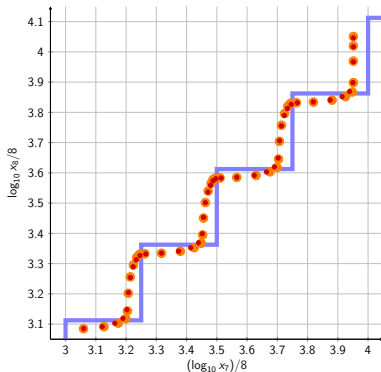

Figure: The successive iterations performed by the predictor-corrector interior point method of Mizuno et al. [1993] on the linear program $\mathbf{LW}_4(t)$ to reduce the duality measure μ from t^2 to 1, when t is equal to 10^8 (left). The points depict the projection of the iterations on the last two coordinates (u_4, v_4) in logarithmic scale (where the logarithm is taken in base t). Orange and red points respectively correspond to prediction and corrections steps. The tropical central path is depicted in blue.